

ARTERIO RS

IVAN CHANDELIER

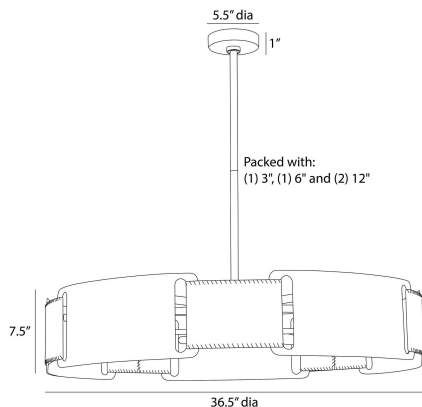

DMI23
Brown, Leather

Whipstitched brown leather straps draw together a blackened hammered iron ring in a mix of texture and material. Reinventing equestrian language for the modern living space, this design plays with negative space via cutouts that allow the light to shine through. Blackened iron pipe and frame. Certified for damp locations and intended for interior use. Finish will vary.

APPEARANCE

Materials	Leather, Iron
Finishes	Brown, Blackened Iron
Finish Will Vary	Yes
Top Coat/Sealant	Yes

DIMENSIONS

Overall	Dia: 36.5 in x H: 11 in
Canopy	Dia: 5.5 in x H: 1 in
Chandelier	Dia: 36.5 in x H: 7.5 in
Overall Hanging Height as Sold (in)	44 in - 11 in

WIRING

Wire Rating	Damp
Cord	10 FT, Black, SVT
Socket	5, Type B - E12
Suggested Bulb Type	T6
Maximum Wattage	40.0
Voltage	110-120 V

CERTIFICATIONS & COMPLIANCY

Certifications	Middle East, European Union, United Kingdom, Mexico, United States, Canada
Compliance	RoHS, UL/ETL, CB

SHIPPING

Product Weight	29.1 lbs
Gross Weight 1	49.72 lbs
Shipping Box 1	W: 11.02 in x D: 38.98 in x H: 38.98 in

CONTRACT

Contract Suitability	Contract Suitable As Is
----------------------	-------------------------

SLOPE CEILING COMPATIBILITY

Sloped Ceiling Compatible	No, is not compatible
---------------------------	-----------------------

COMPONENTS

Pipe or Chain Included	(1) 3", (1) 6", (2) 12"
------------------------	-------------------------

ADDITIONAL PARTS AVAILABLE

PIPE-613	(1) 3", (1) 6", (1) 12"
----------	-------------------------

REPLACEMENT PARTS

PIPE-613
