

ARTERIO RS

ALLENTOWN FLUSH MOUNT

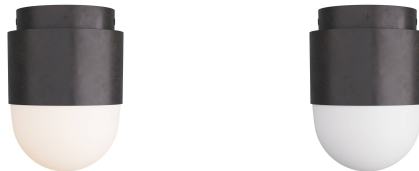
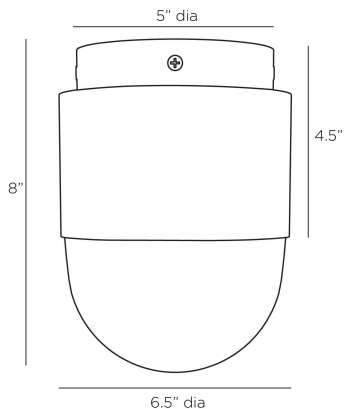

DFC06
English Bronze, Iron

With its simple stepped design and turned metal construction, the Allentown adds a touch of sophisticated industrial design. Its sturdy iron construction is elevated with an elegant finish of English bronze, centered with a cylinder of opal glass. Certified for damp locations and intended for interior use.

APPEARANCE

Materials	Iron, Glass
Finishes	English Bronze, Opal
Finish Will Vary	No
Top Coat/Sealant	Yes

DIMENSIONS

Overall	Dia: 6.5 in x H: 8 in
Canopy	Dia: 5.0 in x H: 1 in

WIRING

Wire Rating	Damp
Cord	0.5 FT, Black/White, SVT
Socket	1, Type A - E26
Suggested Bulb Type	G16.5
Maximum Wattage	60.0
Voltage	110-120 V

CERTIFICATIONS & COMPLIANCY

Certifications	Mexico, United States, Canada
Compliance	RoHS, UL/ETL

SHIPPING

Product Weight	4.3 lbs
Gross Weight 1	8.0 lbs
Shipping Box 1	W: 7.3 in x D: 15.8 in x H: 8.9 in

CONTRACT

Contract Suitability	Contract Suitable As Is
----------------------	-------------------------

REPLACEMENT PARTS

DFC07GLS