

ARTERIO RS

JOSEPH VASES, SET OF 2

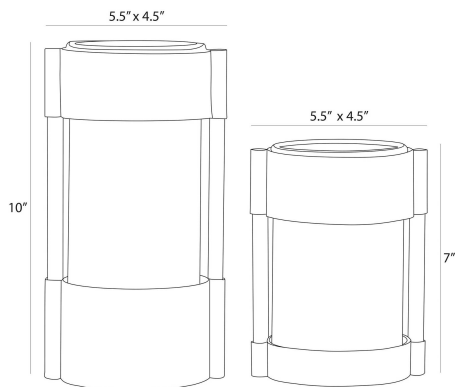

AVI08
Brown, Leather

Drawing from the iconography of the equestrian set, a pair of clear hammered glass vases are suspended in settings of brown leather. Topstitched and held by bronze iron supports, the pair are staggered in height for visual interest. The watertight glass cylinders are removable for cleaning. Finish will vary.

APPEARANCE

Materials	Leather, Glass
Finishes	Brown, Clear
Finish Will Vary	Yes
Top Coat/Sealant	Yes

DIMENSIONS

Overall Large	W: 5.5 in x D: 4.5 in x H: 10 in
Overall Small	W: 5.5 in x D: 4.5 in x H: 7 in
Foot Print Large	W: 5.5 in x D: 4.5 in
Foot Print Small	W: 5.5 in x D: 4.5 in

SHIPPING

Product Weight	5.5 lbs
Gross Weight 1	11.0 lbs
Shipping Box 1	W: 14.96 in x D: 16.93 in x H: 16.93 in

ADDITIONAL INFO

Features	Water Tight
----------	-------------

CONTRACT

Contract Suitability	Contract Suitable As Is
----------------------	-------------------------