

# ARTERIOS

## SHERBOURNE CABINET

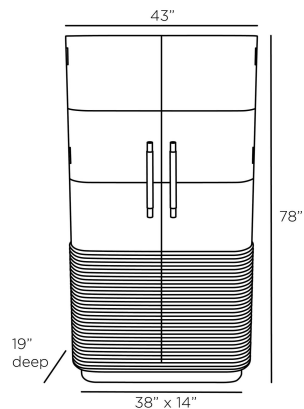

6266  
Graphite, Leather

A study in luxury, this capsule-shaped cabinet was designed to serve capable for general storage. The Sherbourne is wrapped in graphite leather and features white marble door pulls accented in antique brass. Contrasting, oversized ribbing detail finishes the ebony oak base. The piece, which rests on an antique brass plinth, is fitted with a stationery ebony oak veneer interior and shelves, as well as two drawers faced in a matching graphite leather. Finishes will vary.

### APPEARANCE

Materials	Leather, Leather, Oak Wood, Marble, Brass
Finishes	Graphite, Graphite, Ebony, White, Antique Brass
Finish Will Vary	Yes
Top Coat/Sealant	Yes

### DIMENSIONS

Overall	W: 43 in x D: 19 in x H: 78 in
Foot Print	W: 38 in x D: 14 in
Door Shelf	W: 16 in x D: 4 in x H: 2 in
Drawer Interior	W: 14.5 in x D: 11 in x H: 3 in
Shelf	W: 33 in x D: 12.5 in x H: 1 in
Diagonal Dimensions	W: 80.5 in

### SHIPPING

Shipping Requirements	Special Handling Required
Product Weight	334.0 lbs
Gross Weight 1	551.25 lbs
Shipping Box 1	W: 30.0 in x D: 50.0 in x H: 86.0 in

### ADDITIONAL INFO

Shelf Count	10
-------------	----

### CONTRACT

Contract Suitability	Contract Suitable As Is
----------------------	-------------------------

### REPLACEMENT PARTS

6266HNDL