

**SOAP HOLDER /  
CAST / DOUBLE  
DISPENSER**

---

**ACTION: SOAP HOLDER**

---

**KNURL: CAST**

---

**RANGE: BATHROOM**

---

A double-sided soap holder featuring a rough-cast bracket and solid metal bar, with a solid metal disc. All refined by hand.



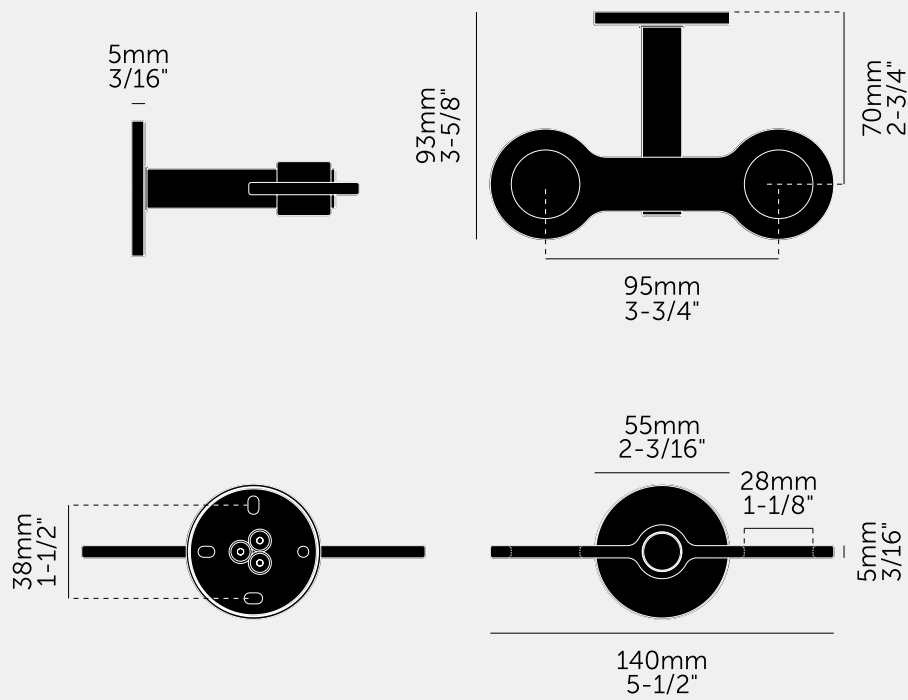

#### SPECIFICATIONS

A double-sided soap holder with cast solid metal bracket, designed for use with Buster + Punch body care bottles. Made with durable finishes that make it suitable for bathroom use.

#### INCLUDED

1 x double-sided soap holder  
 1 x 53mm inner rose cover and washer  
 4 x M4x20mm countersunk woodscrews  
 4 x 30mmx4mm wall plugs

#### PLEASE NOTE

DISCLAIMER: Always consult a trade professional when installing this product. Buster + Punch is not responsible for the usage or feasibility of installation requirements.

#### FINISH & SKU NUMBERS

sku:	finish:	size:
USP-074308	● steel	
USP-484309	● welders black	

#### CARE INSTRUCTIONS

Clean regularly with a soft, dry cloth or duster. Wash periodically using a soft cloth and mild soapy water then dry immediately with a clean, soft cloth. Rubbing or wiping should be carried out in the direction of the polish lines, not across them. DO NOT use oily rags or greasy cloths when wiping the product surface. All finishes prone to ageing.