

**KITCHEN FAUCET /  
PULL-OUT WITH  
DUAL SPRAY /**

---

**ACTION: KITCHEN FAUCET**

---

**KNURL: LINEAR**

---

**RANGE: KITCHEN FAUCETS**

---

A kitchen faucet with single lever mixer and dual spray pull out. This faucet has been cast, sand-blasted and machined from solid metal in Italy. It features our signature linear-knurl pattern and is refined by hand. Flow rate at 58 PSI (4 BAR) is 1.74GPM.



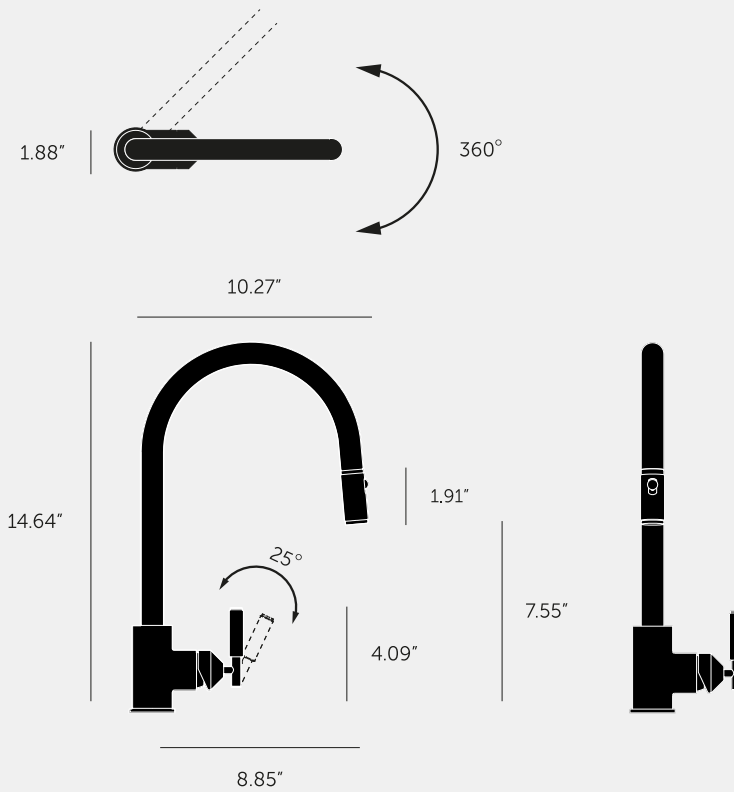

#### SPECIFICATIONS

A kitchen faucet with pull-out and dual spray function, mixing warm and cold, aerated water. The pull-out nozzle can be toggled between aerated or a needle spray. Needle spray covers a wider area than aerated spray. Maximum thickness of mounting surface 70mm, with supplied fixings. Minimum recommended water pressure: 7.25 PSI (0.5 BAR). Maximum recommended water pressure: 72 PSI (5 BAR). Recommended maximum hot water temperature: 70 °C (158°F). Recommended temperature range: 5 – 60 °C (41 – 140 °F). The total length of the pull-out hose is 66.9". Cartridge material: ceramic. 360 degree swivel spout.

Note: Exceeding these temperatures or water pressures can result in damage to the tap. A pressure reducing valve may be required to be fitted in high water pressure situations.

#### FINISH & SKU NUMBERS

sku:	finish:	size:
NKT-053258	● brass	
NKT-353260	● gun metal	
NKT-073259	● steel	
NKT-593261	● welders black	

#### INCLUDED

- 1 x Kitchen Faucet Mixer with Dual Spray Pull-out
- 2 x Flexible connector hoses
- 1 x Kitchen Mixer Faucet
- 1 x Tap Base and set of washers
- 1 x Threaded bar and nut
- 1 x Supporting tap brace (for surfaces with thickness < 5mm)

#### PLEASE NOTE

All Buster + Punch mixer taps conform to standard EN817. In some cases, local housing regulations may require mixer taps to be of a higher minimum water pressure standard. In this instance we would recommend consulting with a certified plumber about installing a pressure regulator or similar device. Mixer taps are tested to work with a max. pressure of 10 bar (1000 kPa) and recommended working pressure range is 1.0 – 5.0 bar (100 kPa – 500 kPa).

#### CARE INSTRUCTIONS

Wipe with damp cloth with no loose hairs, avoid using any chemicals. Please note all finishes are prone to aging.