

# Easyroll 200mm Urethane Cast Iron Swivel Plate X1 Series Castor 2000kg

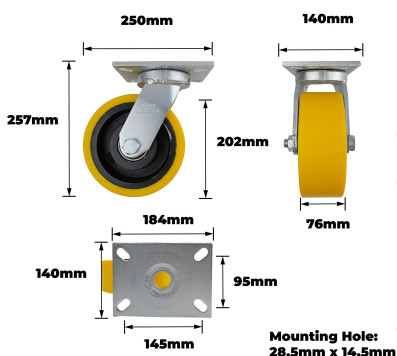

## Description

Easyroll 200mm Urethane Cast Iron Swivel Plate X1 Series Castor 2000kg is engineered with a cast iron wheel core, polyurethane wheel and steel housing for enhanced durability and stability. This castor is designed for steady performance with a precision bearing and plate swivel attachment, making it a practical tool for professionals seeking reliable movement in various settings. The integrated design supports consistent load management for optimal operational efficiency.

## Features

- Robust steel housing ensures long lasting performance
- Cast iron wheel core improves load distribution
- Polyurethane wheel material provides smooth operational movement
- Plate swivel attachment offers versatile installation options
- Accurate precision bearings deliver reliable rotational performance
- Engineered for smooth indoor and outdoor operation
- Single raceway design enhances movement and stability
- Includes plate mount for convenient fitting

**Product Code: X12A91K200**

## Specifications

Outdoor Use	Yes
Indoor Use	Yes
Bearing Type	Precision Bearing
Raceway Type	Single
Attachments	Plate Swivel

## Appearance

Product Colour	Yellow/Black/Silver
----------------	---------------------

## Construction

Wheel Core Material	Cast Iron
Wheel Material	Polyurethane
Housing Material	Steel
Bearing Material	Steel

## Weights

Product Weight (grams)	13031
Product Weight (kg)	13.031
Load Capacity kg	2000.0

## Dimensions

Product Length mm	250
Product Width mm	140
Product Height mm	257
Wheel Diameter	202
Tread Width mm	76
Swivel Radius mm	158
Mounting Hole Dimensions mm	28.5x14.5
Hole Centre Dimensions mm	145x95
Plate Dimensions mm	184x140

NSW/ACT Chris Caruana 0431 151 883 chris.c@ehi.com VIC/TAS/SA Trent Rapp 0412 444 133 trent.p@ehi.com.au  
 QLD Stephen Duncan 0458 203 917 stephen.d@ehi.com.au WA Greg Martin 0417 959 925 greg.m@ehi.com.au