

Easyroll 200mm Red Urethane Swivel Plate Brake J3 Series Castor 400kg

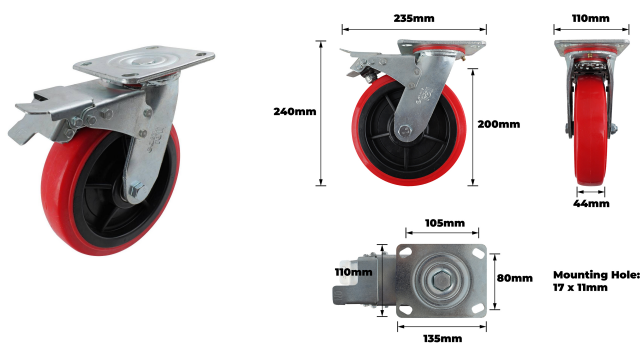

Description

Easyroll 200mm Red Urethane Swivel Plate Brake J3 Series Castor 400kg. This castor is built with a polypropylene wheel core, polyurethane wheel and steel housing with carbon steel bearings, offering dependable movement and braking control. Its ball bearing system and plate swivel fitting deliver smooth rotation and secure mounting for professional applications. The design incorporates red, black and silver accents, providing clear visual identification while enhancing practical performance for trade and industrial professionals.

Features

- Steel housing ensures robust structural support
- Robust ball bearings deliver smooth swivel performance
- Plate mount design facilitates versatile installation
- Red, black and silver finish provides visual appeal
- Polypropylene wheel cores offer lightweight support
- Swivel plate design delivers precise directional control
- Polyurethane wheels enhance durability and load handling
- Outdoor and indoor usability extends application range

Product Code: J32TZ84K200H

Specifications

| | |
|--------------|--------------|
| Outdoor Use | Yes |
| Indoor Use | Yes |
| Bearing Type | Ball Bearing |
| Raceway Type | Single |
| Attachments | Plate Swivel |

Appearance

| | |
|----------------|------------------|
| Product Colour | Red/Black/Silver |
|----------------|------------------|

Construction

| | |
|---------------------|---------------|
| Wheel Core Material | Polypropylene |
| Wheel Material | Polyurethane |
| Housing Material | Steel |
| Bearing Material | Carbon Steel |

Weights

| | |
|------------------------|-------|
| Product Weight (grams) | 3627 |
| Product Weight (kg) | 3.627 |
| Load Capacity kg | 400.0 |

Dimensions

| | |
|-----------------------------|---------|
| Product Length mm | 235 |
| Product Width mm | 110 |
| Product Height mm | 240 |
| Wheel Diameter | 200 |
| Tread Width mm | 44 |
| Swivel Radius mm | 167.5 |
| Mounting Hole Dimensions mm | 17x11 |
| Hole Centre Dimensions mm | 105x80 |
| Plate Dimensions mm | 135x110 |

NSW/ACT Chris Caruana 0431 151 883 chris.c@ehi.com VIC/TAS/SA Trent Rapp 0412 444 133 trent.p@ehi.com.au
 QLD Stephen Duncan 0458 203 917 stephen.d@ehi.com.au WA Greg Martin 0417 959 925 greg.m@ehi.com.au

www.ehi.com.au

For all enquiries please contact our customer service team on 1300 727 535 or at cs@ehi.com.au

