

# Colson 125mm Red Urethane Swivel Plate Brake I3 Series Castor 250kg

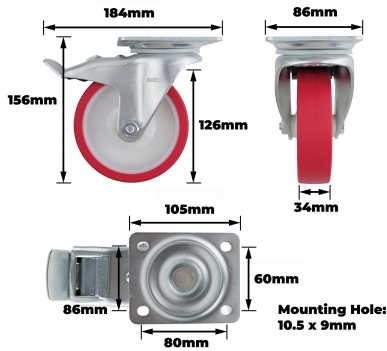

## Description

Colson 125mm Red Urethane Swivel Plate Brake I3 Series Castor 250kg features a robust steel housing and ball bearing mechanism, ensuring smooth swivelling support. Its red urethane wheel paired with a thermoplastic rubber element offers consistent performance for various applications. The plate mount design facilitates secure installation, while the total brake mechanism provides precise control. With a 250kg capacity, this castor delivers reliable movement management for trade professionals.

## Features

- Robust steel housing ensures stable support
- Red urethane wheel ensures superior traction
- Low friction ball bearings provide smooth swivel motion
- Total brake delivers controlled stopping performance
- Plate mounting offers secure and fast installation
- Plastic wheel core contributes to overall weight savings
- Swivel design offers agile movement
- Versatile performance for varied application surfaces

**Product Code: I32TZ-UL8K125**

## Specifications

Outdoor Use	Yes
Indoor Use	Yes
Bearing Type	Ball Bearing
Raceway Type	Single
Brake Type	Total

## Appearance

Product Colour	Red
----------------	-----

## Construction

Wheel Core Material	Plastic
Wheel Material	Thermoplastic Rubber
Housing Material	Steel
Bearing Material	Steel

## Weights

Product Weight (grams)	1418
Product Weight (kg)	1.418
Load Capacity kg	250.0

## Dimensions

Product Length mm	184
Product Width mm	86
Product Height mm	156
Wheel Diameter	126
Tread Width mm	34
Swivel Radius mm	131.5
Mounting Hole Dimensions mm	10.5x9
Hole Centre Dimensions mm	80x60
Plate Dimensions mm	105x86

NSW/ACT Chris Caruana 0431 151 883 chris.c@ehi.com VIC/TAS/SA Trent Rapp 0412 444 133 trent.p@ehi.com.au  
 QLD Stephen Duncan 0458 203 917 stephen.d@ehi.com.au WA Greg Martin 0417 959 925 greg.m@ehi.com.au

[www.ehi.com.au](http://www.ehi.com.au)

For all enquiries please contact our customer service team on 1300 727 535 or at [cs@ehi.com.au](mailto:cs@ehi.com.au)

