

# Colson 100mm Green Rubber Swivel Plate Brake I3 Series Castor 170kg

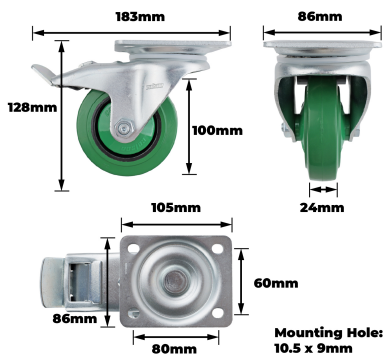

## Description

Colson 100mm Green Rubber Swivel Plate Brake I3 Series Castor 170kg is a castor engineered with a plate mount assembly, featuring a robust steel housing and ball bearings. Its 100mm green elastic rubber wheel with a plastic core enables precise manoeuvrability and steady load distribution. The total brake system facilitates secure positioning for trade professionals seeking dependable movement and control in their applications.

## Features

- Durable steel housing withstands regular operational stresses
- Ball bearing system ensures smooth caster movement
- Green rubber wheel provides high traction on varied surfaces
- Total brake stops caster rotation instantly
- Plate mount fitting ensures secure and stable caster installation
- Rubber wheel core plastic design minimises maintenance and downtime
- Lightweight yet robust construction supports high load capacity
- Designed for reliable performance in varied usage conditions

**Product Code: I32TZ-KL7K100**

## Specifications

Outdoor Use	Yes
Indoor Use	Yes
Bearing Type	Ball Bearing
Raceway Type	Single
Brake Type	Total

## Appearance

Product Colour	Green
----------------	-------

## Construction

Wheel Core Material	Plastic
Wheel Material	Rubber
Housing Material	Steel
Bearing Material	Steel

## Weights

Product Weight (grams)	1287
Product Weight (kg)	1.287
Load Capacity kg	170.0

## Dimensions

Product Length mm	183
Product Width mm	86
Product Height mm	128
Wheel Diameter	100
Tread Width mm	24
Swivel Radius mm	130.5
Mounting Hole Dimensions mm	10.5x9
Hole Centre Dimensions mm	80x60
Plate Dimensions mm	105x86

NSW/ACT Chris Caruana 0431 151 883 chris.c@ehi.com  
 QLD Stephen Duncan 0458 203 917 stephen.d@ehi.com.au

VIC/TAS/SA Trent Rapp 0412 444 133 trent.p@ehi.com.au  
 WA Greg Martin 0417 959 925 greg.m@ehi.com.au

[www.ehi.com.au](http://www.ehi.com.au)

For all enquiries please contact our customer service team  
 on 1300 727 535 or at [cs@ehi.com.au](mailto:cs@ehi.com.au)

