

Easyroll 125mm Grey Rubber Swivel Plate G7 Series Castor 100kg

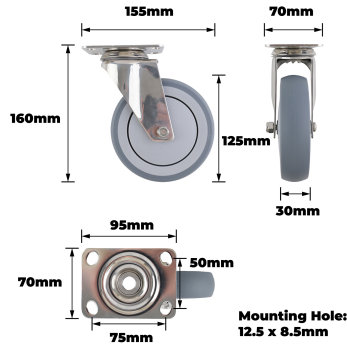

Description

Easyroll 125mm Grey Rubber Swivel Plate G7 Series Castor 100kg is a precision-engineered castor featuring a nylon wheel core, thermoplastic rubber wheel and robust steel housing. Designed for controlled manoeuvring of heavy loads, it employs ball bearing technology and a plate swivel attachment for enhanced movement. This castor offers dependable performance and durability, delivering valuable benefits to industrial and trade professionals during material handling and equipment mobility tasks.

Features

- High-strength steel housing ensures durability
- Nylon core wheel supports robust load capacity
- Thermoplastic rubber wheel provides reliable traction
- Ball bearing design enables smooth rotation
- Simple single raceway supports stable performance
- Plate mount and swivel allow versatile installation
- Engineered for indoor and outdoor use
- Available in grey, silver and red colour options

Product Code: G72AS62K125

Specifications

Outdoor Use	Yes
Indoor Use	Yes
Bearing Type	Ball Bearing
Raceway Type	Single
Attachments	Plate Swivel

Appearance

Product Colour	Grey/Silver/Red
----------------	-----------------

Construction

Wheel Core Material	Nylon
Wheel Material	Thermoplastic Rubber
Housing Material	Steel
Bearing Material	Stainless Steel

Weights

Product Weight (grams)	806
Product Weight (kg)	0.806
Load Capacity kg	100.0

Dimensions

Product Length mm	155
Product Width mm	70
Product Height mm	162
Wheel Diameter	125
Tread Width mm	32
Swivel Radius mm	107.5
Mounting Hole Dimensions mm	12.5x8.9
Hole Centre Dimensions mm	74x48
Plate Dimensions mm	95x70

NSW/ACT Chris Caruana 0431 151 883 chris.c@ehi.com VIC/TAS/SA Trent Rapp 0412 444 133 trent.p@ehi.com.au
 QLD Stephen Duncan 0458 203 917 stephen.d@ehi.com.au WA Greg Martin 0417 959 925 greg.m@ehi.com.au

www.ehi.com.au

For all enquiries please contact our customer service team on 1300 727 535 or at cs@ehi.com.au

