

# Easyroll 125mm Grey Rubber Swivel Brake G6 Series Castor 130kg

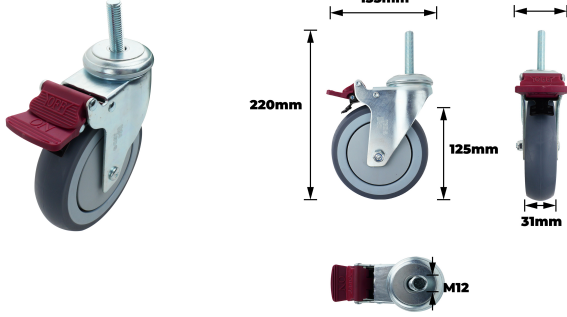

## Description

Easyroll 125mm Grey Rubber Swivel Brake G6 Series Castor 130kg is engineered with a polypropylene wheel core and thermoplastic rubber wheels, supported by a durable steel housing and quality bearing steel ball bearings. The total braking system paired with a single raceway design and bolt fitting provides precise manoeuvrability and secure installation, offering a reliable material handling solution for trade professionals in demanding applications.

## Features

- Robust steel housing with secure bolt fitting
- Polypropylene core supports consistent load performance
- Thermoplastic rubber wheel provides low friction movement
- Precision ball bearings ensure stable rolling action
- Total brake system offers full mobility control
- Compact design with single raceway enhances wear resistance
- Engineered for outdoor use with robust load capacity
- Distinct colour scheme aids easy product identification

**Product Code: G64TZ44K125**

## Specifications

Outdoor Use	Yes
Indoor Use	No
Bearing Type	Ball Bearing
Raceway Type	Single
Brake Type	Total
Fitting Type	Bolt Hole

## Appearance

Product Colour	Grey/Silver/Red
----------------	-----------------

## Construction

Wheel Core Material	Polypropylene
Wheel Material	Thermoplastic Rubber
Housing Material	Steel
Bearing Material	Bearing Steel

## Dimensions

Product Length mm	135
Product Width mm	58
Product Height mm	220
Wheel Diameter	127
Tread Width mm	31
Finish Height mm	160
Bolt Thread Length (mm)	75
Bolt Thread Width (mm)	12
Mounting Size (G) mm	M12

NSW/ACT Chris Caruana 0431 151 883 chris.c@ehi.com VIC/TAS/SA Trent Rapp 0412 444 133 trent.p@ehi.com.au  
 QLD Stephen Duncan 0458 203 917 stephen.d@ehi.com.au WA Greg Martin 0417 959 925 greg.m@ehi.com.au

[www.ehi.com.au](http://www.ehi.com.au)

For all enquiries please contact our customer service team on 1300 727 535 or at [cs@ehi.com.au](mailto:cs@ehi.com.au)

