

Easyroll 100mm Grey Rubber Swivel Brake G6 Series Castor 120kg

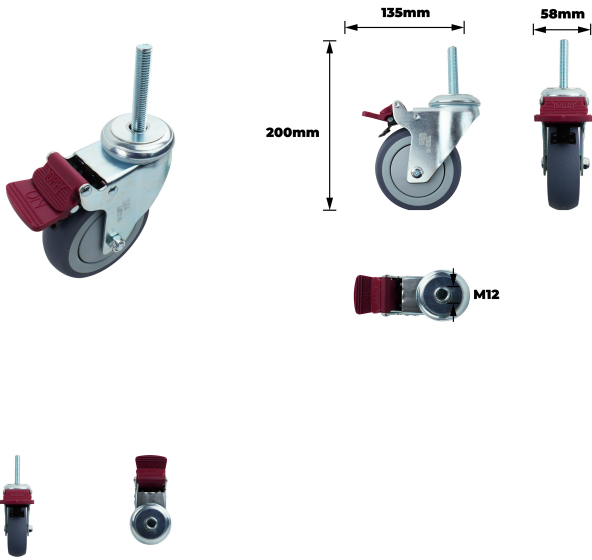

Description

Easyroll 100mm Grey Rubber Swivel Brake G6 Series Castor 120kg is engineered to deliver precise mobility with a polypropylene wheel core and a thermoplastic rubber wheel. Its steel housing and ball bearing assembly provide a robust structure, while the bolt fitting and single raceway design ensure secure installation and controlled movement. The total brake mechanism offers consistent stopping power, supporting the practical requirements of trade professionals in demanding applications.

Features

- Thermoplastic rubber wheel provides wear resistance under heavy loads
- Wheel core manufactured in polypropylene for structural integrity
- Steel housing delivers robust support and durability
- Bearing steel and ball bearings ensure smooth swivel rotation
- Total brake provides confident stopping control
- Bolt hole fitting allows secure installation in varying applications
- Constructed with precision to support a 120kg load
- Available in grey, silver, and red for versatility

Product Code: G64TZ44K100

Specifications

Outdoor Use	Yes
Indoor Use	No
Bearing Type	Ball Bearing
Raceway Type	Single
Brake Type	Total
Fitting Type	Bolt Hole

Appearance

Product Colour	Grey/Silver/Red
----------------	-----------------

Construction

Wheel Core Material	Polypropylene
Wheel Material	Thermoplastic Rubber
Housing Material	Steel
Bearing Material	Bearing Steel

Dimensions

Product Length mm	135
Product Width mm	58
Product Height mm	200
Wheel Diameter	100
Tread Width mm	28
Finish Height mm	135
Bolt Thread Length (mm)	75
Bolt Thread Width (mm)	12
Mounting Size (G) mm	M12

NSW/ACT Chris Caruana 0431 151 883 chris.c@ehi.com VIC/TAS/SA Trent Rapp 0412 444 133 trent.p@ehi.com.au
 QLD Stephen Duncan 0458 203 917 stephen.d@ehi.com.au WA Greg Martin 0417 959 925 greg.m@ehi.com.au