

Easyroll 100mm Grey Rubber Swivel Plate G6 Series Castor 120kg

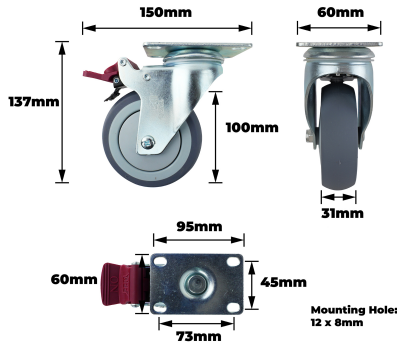

Description

Easyroll 100mm Grey Rubber Swivel Plate G6 Series Castor 120kg is designed for indoor use with a focus on technical performance and durability. It features a steel housing, single raceway ball bearing, and polypropylene core combined with thermoplastic rubber wheels, ensuring reliable load distribution. The castor's plate mount and rigid plate attachment provide secure fixation, making it suitable for trade professionals seeking consistent movement and precise positioning in various equipment applications.

Features

- High load capacity with a 120kg rating
- Durable thermoplastic rubber wheels for smooth manoeuvring
- Single raceway ball bearing system ensures reliable rotation
- Polypropylene wheel cores enhance overall structural integrity
- Rigid plate mount provides secure and steadfast installation
- Swivel design offers improved mobility and precise control
- Steel housing with bearing steel components maximises longevity
- Grey, silver and red finish offers clear visual contrast

Product Code: G62TZ44K100

Specifications

Outdoor Use	No
Indoor Use	Yes
Bearing Type	Ball Bearing
Raceway Type	Single
Attachments	Plate Rigid

Appearance

Product Colour	Grey/Silver/Red
----------------	-----------------

Construction

Wheel Core Material	Polypropylene
Wheel Material	Thermoplastic Rubber
Housing Material	Steel
Bearing Material	Bearing Steel

Weights

Product Weight (grams)	830
Product Weight (kg)	0.83
Load Capacity kg	120.0

Dimensions

Product Length mm	150
Product Width mm	61
Product Height mm	137
Wheel Diameter	100
Tread Width mm	31
Swivel Radius mm	104
Mounting Hole Dimensions mm	12x8
Hole Centre Dimensions mm	73x45
Plate Dimensions mm	93x61

NSW/ACT Chris Caruana 0431 151 883 chris.c@ehi.com VIC/TAS/SA Trent Rapp 0412 444 133 trent.p@ehi.com.au
 QLD Stephen Duncan 0458 203 917 stephen.d@ehi.com.au WA Greg Martin 0417 959 925 greg.m@ehi.com.au

www.ehi.com.au

For all enquiries please contact our customer service team on 1300 727 535 or at cs@ehi.com.au

