

Easyroll 50mm Grey Urethane Swivel Plate Brake G1 Series Castor 40kg

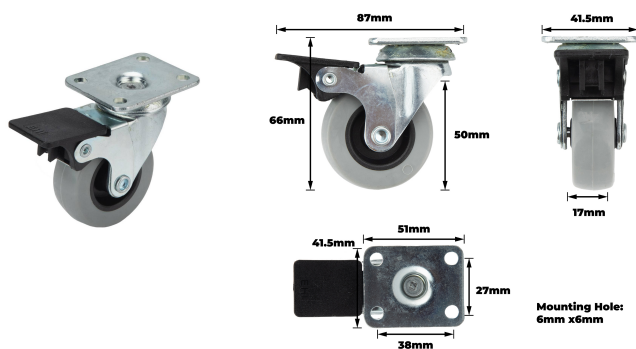

Description

Easyroll 50mm Grey Urethane Swivel Plate Brake G1 Series Castor 40kg is a plate mount castor featuring a steel housing, steel bearings, and a polypropylene wheel core that supports a thermoplastic rubber wheel. The unit is designed for precise manoeuvring on indoor surfaces using a plain bearing and a single raceway. Its integrated brake and rigid plate attachment offer controlled movement and dependable performance for trade professionals requiring practical and efficient solutions.

Features

- Steel housing and bearings offer robust mechanical integrity
- Thermoplastic rubber wheels provide low friction movement
- Polypropylene wheel core enhances performance efficiency
- Rigid plate mount supports secure and precise installation
- Single raceway design improves directional stability
- Designed for indoor use with smooth mobility
- Plain bearing design minimises friction and wear
- Integrated brake limits unwanted castor rotation

Product Code: G12W33G50

Specifications

Outdoor Use	No
Indoor Use	Yes
Bearing Type	Plain Bearing
Raceway Type	Single
Attachments	Plate Rigid

Appearance

Product Colour	Grey/Black/Silver
----------------	-------------------

Construction

Wheel Core Material	Polypropylene
Wheel Material	Thermoplastic Rubber
Housing Material	Steel
Bearing Material	Steel

Weights

Product Weight (grams)	160
Product Weight (kg)	0.16
Load Capacity kg	40.0

Dimensions

Product Length mm	87
Product Width mm	42
Product Height mm	66
Wheel Diameter	50
Tread Width mm	17
Swivel Radius mm	61.5
Mounting Hole Dimensions mm	6.0x6
Hole Centre Dimensions mm	38x27
Plate Dimensions mm	51x42

NSW/ACT Chris Caruana 0431 151 883 chris.c@ehi.com VIC/TAS/SA Trent Rapp 0412 444 133 trent.p@ehi.com.au
 QLD Stephen Duncan 0458 203 917 stephen.d@ehi.com.au WA Greg Martin 0417 959 925 greg.m@ehi.com.au