

2-Way N Power Divider From 0.5 GHz to 6 GHz Rated at 30 Watts

P/N: GPD-2N-005060-E

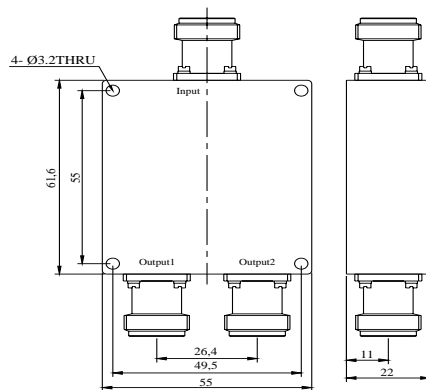

Dimensions are in mm



## Product Configuration

Connector-In Series	N
Connector-In Polarity	Standard
Connector-In Gender	Female
Connector-In Impedance (Ohm)	50
Connector-Out Series	N
Connector-Out Polarity	Standard
Connector-Out Gender	Female
Connector-Out Impedance (Ohm)	50

## Electrical Specifications

Insertion Loss	≤1.2
Power, Max Input (Watts)	30
VSWR, Max Input	1.25
Frequency Range	0.5-6GHz
VSWR, Max Output	1.2
Amplitude Balance (dB)	±0.2
Phase Balance (°)	±3
Isolation Min.(dB)	20

## Mechanical Data

Mating Cycles, Min	≥500
Weight (g)	168.4 g
Colour	Grey
Housing Material	Aluminum

## 2-Way N Power Divider From 0.5 GHz to 6 GHz Rated at 30 Watts

P/N: GPD-2N-005060-E

### Environmental Specifications

RoHS Compliant

Yes

Operating Temperature Range

-35 °C to +75 °C

### Test Data

